

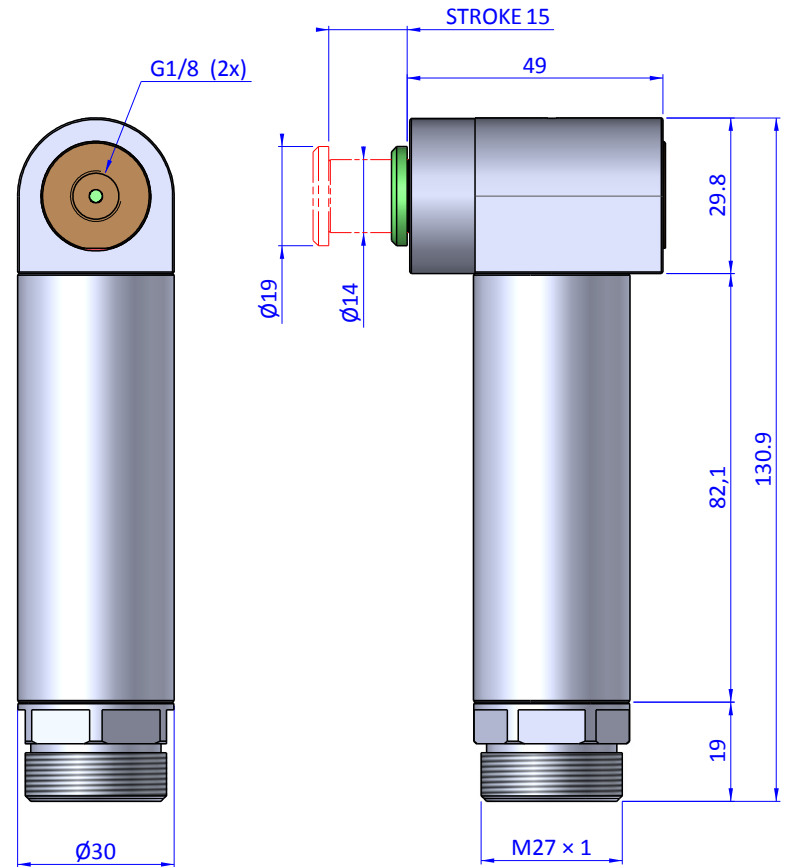

THE PROPERTY OF THE DRAWING IS ESTABLISHED BY LAW. IT IS FORBIDDEN TO PRODUCE OR SHOW IT TO THIRD PARTY, WITHOUT A WRITTEN AGREEMENT.

Item	Name	Q.ty
1	GRF30.95.01	1
2	GRF30.95.02	1
3	GRF30.95.03.2	1
4	GRF30.95.10	1
5	M.16x35	1
6	M.24X66	1
7	OR.119	1
8	PMA.3015.1	1
9	PMA.3015.2	1
10	PMA.3015.3	1
11	PPS.3015.07.V	1
12	PSP.251935	1

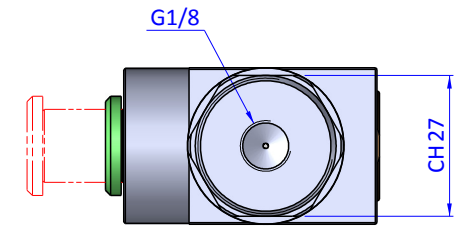
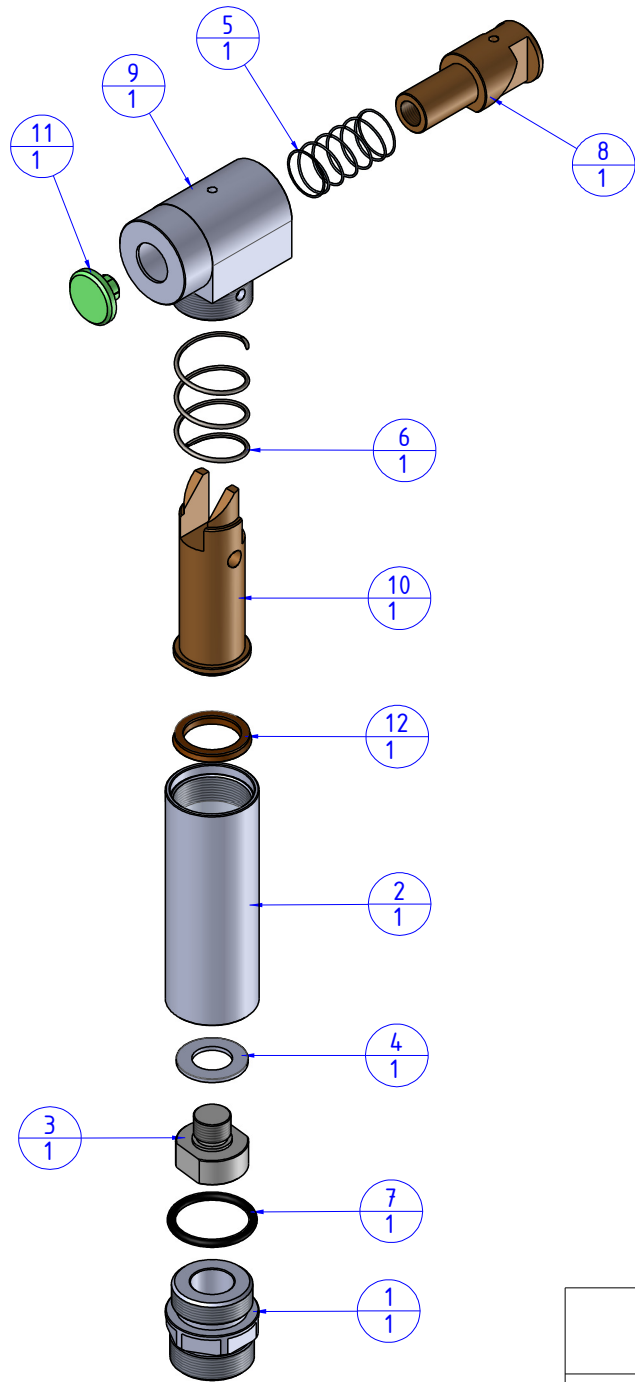

Format A3

UNI 936-76

 <b>FPS</b> FPSERVICES AUTOMATION		DESIGNED FROM	REVIEW
		FPS Automation	A
GENERAL TOLERANCE	DESCRIPTION	DATE	WEIGHT
UNI - ISO 2768	CA.PMA.3015	31/07/2019	0,366kg
CLASSE F		CODE	
		CA.PMA.3015	